



**WTD PTO  
MECHANICAL POWER TAKE OFF**

**INSTALLATION AND  
MAINTENANCE MANUAL**



**WPT Power Corporation**  
1600 Fisher Road - Wichita Falls, TX 76305  
P.O. Box 8148 - Wichita Falls, TX 76307  
Ph. 940-761-1971 Fax 940-761-1989  
[www.WPTpower.com](http://www.WPTpower.com)



## Table of Contents

	Page#
<b>1.0 INTRODUCTION</b> .....	<b>4</b>
1.1 The WPT Power Corporation PTO	
1.2 Product identification numbers	
1.3 Bill of materials	
<b>2.0 SPECIFICATIONS</b> .....	<b>4</b>
2.1 Flywheel dimensions	
2.2 Flywheel housing / Bell housing dimensions	
2.3 PTO performance table	
<b>3.0 LUBRICATION</b> .....	<b>4</b>
3.1 Lubrication prior to installation	
3.2 Release mechanism lubrication	
3.3 Main bearings and lever shaft lubrication	
3.4 Amount and frequency of lubrication	
<b>4.0 INSPECTION</b> .....	<b>4</b>
4.1 Preparation	
4.2 Flywheel and flywheel housing checks	
4.3 Flywheel to housing face run out	
4.4 Flywheel housing bore run out	
4.5 Flywheel face run out	
4.6 Engine crankshaft endplay	
4.7 Flywheel pilot bore run out	
<b>5.0 INSTALLATION</b> .....	<b>6</b>
5.1 Clutch disc alignment	
5.2 Clutch engagement	
5.3 Drive ring installation	
5.4 Pilot bearing installation	
5.5 PTO installation	
5.6 Interference check	
5.7 Bell housing bolt torques	
5.8 Relieve bearing preload	
5.9 Install operating handle	
5.10 Check relief from bearing preloading	
5.11 Recheck crankshaft endplay	
5.12 Support plate requirements	
<b>6.0 CLUTCH OPERATION</b> .....	<b>8</b>
6.1 Engaging the clutch	
6.2 Fully engaged clutch	
<b>7.0 PTO ADJUSTMENT</b> .....	<b>8</b>
7.1 Clutch adjustment	
7.2 Main bearing adjustment	
<b>8.0 DISASSEMBLY</b> .....	<b>10</b>
8.1 Remove PTO from engine	
8.2 Remove clutch from PTO	
8.3 Remove shaft from PTO housing	
<b>9.0 ASSEMBLE PTO</b> .....	<b>11</b>

## Table of Contents

10.0	WARRANTY .....	12
11.0	Chart 1 - Bolt Torque Values .....	13
12.0	Chart 2 - Specifications and Duty Service Classification .....	14
13.0	Chart 3 - Flywheel and Housing Dimensions .....	15
14.0	Flywheel and Housing Drawing .....	16
15.0	WTD-SP Style PTO Exploded View Drawing .....	17
16.0	WTD-SP Style PTO Drawing and Parts List .....	18
17.0	WTD-C Style PTO Drawing and Parts List .....	19
18.0	WTD-SP Style 18" PTO Drawing and Parts List .....	20

## 1.0 Introduction

- 1.1 The WPT Power Corporation PTO is the most rugged PTO available on the market today. Follow the procedures detailed in this Installation Maintenance Manual for years of service.
- 1.2 When ordering parts, use the part number from the Bill of Materials supplied with this unit. Also, please include the part number and the serial number from the unit itself. These will be found on the metal hand hole cover on the bell housing. Your WPT Distributor can provide a copy of the Bill of Materials if the one provided should become lost.
- 1.3 When performing installation and maintenance functions, refer to the drawings at the back of this manual, pages 17 thru 20. The references on the drawing in this manual DO NOT correspond to the references on the assembly drawing and Bill of Materials. Do not use the item numbers from the drawing in this manual for ordering parts.

## 2.0 Specifications

- 2.1 See Chart 3 for flywheel dimensions, page 15 and drawing page 16.
- 2.2 See Chart 3 for flywheel housing dimensions, page 15 and drawing page 16.
- 2.3 The maximum RPM is listed in Chart 2 for your PTO size, page 14.

## 3.0 Lubrication

- 3.1 The WPT mechanical PTO requires lubrication with NLGI #2 lithium based grease. Prior to installation, grease the main shaft bearings, sliding sleeve assembly, and operating shaft. Apply grease to each fitting until grease just appears at the respective seal surfaces. Although the PTO is normally lubricated at the factory, this step will insure that all moving parts are properly lubricated for initial use.
- 3.2 During normal operation, apply one grease gun shot of grease to the release mechanism (sliding sleeve assembly) fitting every 20 hours of operation.
- 3.3 Also lubricate the main bearings (located on the clutch shaft) and lever (operating) shaft every 100 hours of operation with one grease gun shot.
- 3.4 Amount and frequency of lubrication are only a recommendation. Actual requirements will vary, due to load and operating conditions. New units should be monitored for heat and wear for a period of time, to determine actual needs.

**NOTE:** Pilot bearing is “sealed for life” and does not require lubrication.

## 4.0 Inspection

- 4.1 **Preparation.** Upon receipt of your WPT product, inspect for and report any evidence of damage. To avoid damage or personal injury, insure that adequate lifting devices and hand tools are available. Compare the flywheel, flywheel housing, and pilot bearing bore to the bell housing, drive ring, and pilot bearing, respectively to insure that you have the correct size unit.

**4.2 Check flywheel and flywheel housing alignment.** It is strongly recommended that dial indicator checks be made prior to installation of the PTO, especially on new engines or when a previous PTO failure might indicate an alignment problem.

**4.3 Flywheel to housing face runout check.**

Mount the indicator base on the face of the flywheel and position the dial indicator tip perpendicular to the flywheel housing mounting face. Rotate the flywheel 360 degrees while holding pressure against the crankshaft thrust bearing. The total indicator reading should not exceed the values listed in the table shown below in Section 4.4.

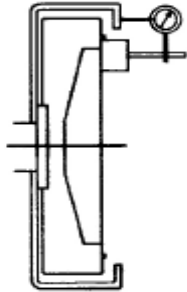

**4.4 Check flywheel housing bore runout.** Mount the indicator base on the face of the flywheel and position the dial indicator tip so its movement is perpendicular to the pilot bore of the flywheel housing. Rotate the flywheel through 360 degrees.

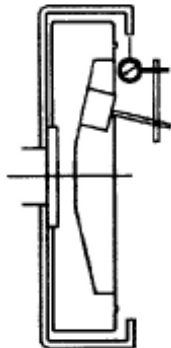

The total indicator reading should not exceed :

SAE "00" Housing:	0.019 inches (0.483 mm)
SAE ".0" Housing:	0.016 inches (0.406 mm)
SAE ".1" Housing:	0.012 inches (0.305 mm)
SAE ".2" Housing:	0.011 inches (0.279 mm)
SAE ".3" Housing:	0.010 inches (0.254 mm)
SAE ".4" Housing:	0.009 inches (0.229 mm)
SAE ".5" Housing:	0.008 inches (0.203 mm)
SAE ".6" Housing:	0.007 inches (0.178 mm)

(Reference: SAE J617 table 1A)

**4.5 Check flywheel face runout.**

Mount the indicator base on the flywheel housing and position the dial indicator tip so that its movement is perpendicular to the face of the flywheel. Position the indicator tip near the drive ring mounting bolt circle diameter. Rotate the flywheel 360 degrees while holding pressure against the crankshaft thrust bearing.

The total indicator reading should not exceed 0.0005 inches (0.013 mm) per inch of measured diameter.

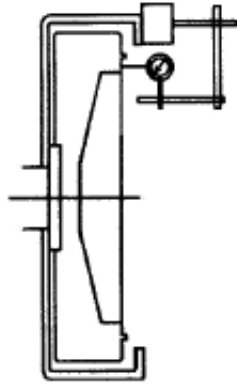

#### 4.6 Check engine crankshaft endplay.

Measure and document the engine's crankshaft endplay before installing PTO. Using dial indicator as shown in 4.5 move the crankshaft back against the rear main bearing and then move the crankshaft to the front of the engine. Record the total movement as shown by the dial indicator.

#### 4.7 Check flywheel pilot bore runout.

Mount the indicator base on the flywheel housing and position the dial indicator tip so its movement is perpendicular to the pilot bore diameter, to measure pilot bore runout. Rotate the flywheel through 360 degrees.

The total indicator reading should not exceed 0.005 inches (0.127 mm).

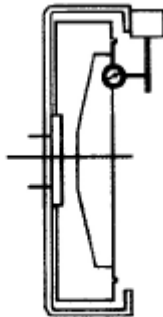

## 5.0 Installation

- 5.1 Use the drive ring provided with the PTO or remove the drive ring from the engine flywheel to use as an alignment gauge. Place the drive ring over the friction discs. Center the drive ring relative to the O.D. of the clutch body. Engage the clutch by operating the hand lever.
- 5.2 Remove the drive ring. Do not disengage clutch until installation is complete.
- 5.3 Install the drive ring on the engine flywheel making sure that the ring is seated in the locating bore. Use SAE Grade 5 bolts (or equivalent) with lock washers and torque to the specifications in Chart 1 on page 13 or to the engine manufacturers torque recommendation. Use the engine manufacturer's torque recommendation if different from that in Chart 1.

- 5.4 Install pilot bearing onto clutch end of PTO shaft, stopping before the bearing is flush with the shaft. Let the bearing overhang the shaft by 1/8". Only apply force on the inner race of the bearing.
- 5.5 Remove inspection cover nameplate from the PTO bellhousing and slowly draw the PTO toward the engine; this can be done by installing 3 or 4 equally spaced lengths of all-thread into the flywheel housing. Install nuts and tighten these while supporting the weight of the PTO with a hoist or cribbing.
- 5.6 As the PTO is drawn toward the engine, insure that the pilot bearing engages the crankshaft, and the friction discs engage the teeth on the drive ring without binding or interference.
- 5.7 When the PTO is fully in place, remove the studs if used and replace with SAE Grade 5 bolts (or equivalent) with lock washers and torque to the value in Chart 1 on page 13. Use the engine manufacturer's torque recommendation if different from that in Chart 1.
- 5.8 Strike the output end of clutch shaft with a soft face hammer to relieve bearing preloading caused by installation, see sketch below.

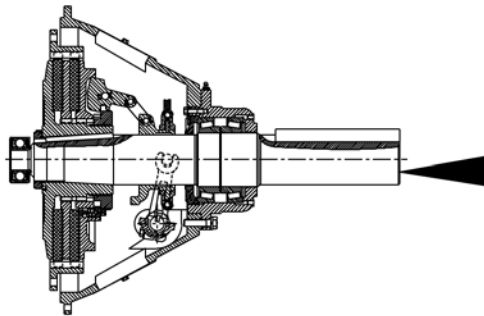

**STRIKE HERE IN  
THIS DIRECTION**

- 5.9 The operating handle (hand lever) may be installed on either side of the PTO engagement shaft, depending upon space requirements and convenience to the operator. Install lever with the cast hex facing away from the PTO.

**! WARNING:** Operating handle must be mounted in the vertical position to eliminate excessive wear in the collar, see drawings on pages 18, 19 and 20.

- 5.10 To check relief from bearing preloading, engage the clutch, then move the hand lever back and forth to feel the bearing endplay. Shaft and clutch should move .003" to .010".
- 5.11 Re-check crankshaft endplay. If not the same as recorded in 4.6, STOP and determine the cause. Crankshaft and clutch shaft must have the proper amount of endplay or bearings may fail.
- 5.12 Support plate is required for SP311/214/314 side load applications and recommended for in-line applications. Support plate is required for all 18" applications.

**! WARNING:**

The WPT mechanical PTO is capable of side load and inline power transmission applications. Special care should be exercised when installing the PTO in an inline application. Due to engine movement and other factors that may cause misalignment, WPT recommends that a flexible coupling or drive shaft be used to join the PTO and driven shaft. If a coupling is used, insure that it has sufficient horsepower capacity and that shafts are in line within the limits

specified by the coupling manufacturer. If you are unsure about the procedure to align these shafts, consult the coupling manufacturer or WPT Power Transmission Corp.

## 6.0 Clutch Operation

- 6.1 Where high inertia loads must be started, engaging the clutch at idle speed may stall the engine. High inertia loads may be brought up to speed by engaging the clutch for short periods (1 second) at intervals long enough to prevent excessive heat build up in the friction discs. With extremely high loads, the engine may have to be operated at higher speeds while engaging the clutch.
- 6.2 Once the load is turning with the clutch fully engaged, the engine RPM may be increased.



### **WARNING:**

UNDER NO CIRCUMSTANCES should the clutch be slipped for more than four seconds maximum without either fully engaging the clutch or completely disengaging the clutch to allow it to cool. Any excessive vibration in the PTO should be cause for investigation. All rotating parts of the WPT PTO are balanced at the factory.

## 7.0 PTO Adjustment

### 7.1 Clutch Adjustment

The WPT mechanical PTO uses an adjusting collar to adjust for clutch wear. If the engagement force reaches 2/3 of maximum specified torque, clutch slips, heats excessively, or operating lever fails to stay engaged, clutch adjustment is required.

- 7.1.1 Remove inspection cover nameplate.
- 7.1.2 Disengage locking pin for "SP" style clutches by pushing pin in with a screwdriver. For "C" style clutches pull locking pin out.
- 7.1.3 Turn adjusting ring clockwise to increase clutch engagement force.
- 7.1.4 Adjust clutch engagement force until the hand lever force required to engage the clutch is within the range specified on the inspection cover nameplate. Check engagement force with a torque wrench using the cast hex on the lever.
- 7.1.5 Release lock pin after completing adjustment.
- 7.1.6 Replace inspection cover nameplate.

**NOTE:** New friction discs require frequent adjustments during an initial break-in period. Please recheck clutch adjustment after the first 10 hours of operation.

### **Clutch Adjustment Frequency**

- 7.1.7 As clutch wears, the hand lever force required to engage clutch will decrease.



7.1.8 The need to readjust the clutch is indicated when the handle force has decreased to 2/3 of the maximum force specified on the inspection cover plate **OR** anytime clutch slippage is detected.

7.1.9 Do not adjust clutch so tight that hand lever force exceeds the maximum as indicated on the inspection cover nameplate.



**WARNING:** Do not use any automated clutch engagement device which continues to apply pressure to the hand lever, after clutch is engaged. To prevent excessive wear to clutch sliding sleeve and other clutch parts, the hand lever should be allowed to rest in a vertical position with no external force applied to it once clutch is engaged.

## 7.2 Main Bearing Adjustments

7.2.1 PTO main bearings should be adjusted to provide .007" - .009" axial clearance in main shaft for 106 thru 211 PTO's and .009" - .012" axial clearance in main shaft for 311 thru 314 PTO's (18" PTO's do not have an adjustment).

7.2.2 Place PTO so the bellhousing flange supports its weight.

7.2.3 Mount dial indicator base on PTO housing.

7.2.4 Place dial indicator stem on end of shaft in a manner that will gauge shaft axial endplay.

7.2.5 Apply 200 lbs of "upward" force on shaft using a suitable hoist and lift device to fit the tapped hole in the end of the shaft.

7.2.6 Rotate shaft several revolutions.

7.2.7 Zero dial indicator reading.

7.2.8 Remove hoist from shaft and apply 200 lbs of "downward" force on shaft.

7.2.9 Rotate shaft several revolutions.

7.2.10 Read axial endplay from dial indicator.

7.2.11 Loosen bearing adjustment lock on inside of bell housing.

7.2.12 Rotate bearing locknut until proper shaft axial endplay is obtained.

**NOTE:** When loosening nut, strike output end of shaft with a soft face hammer to set bearing cup (outer race) against adjusting nut. See sketch on page 7 for direction.

7.2.13 Adjust bearing locknut until nearest notch lines up with tab on bearing adjustment lock.

7.2.14 Tighten bearing adjustment lock.

## 8.0 Disassembly

(Refer to PTO Illustration on pages 17, 18, 19 and 20 of this manual)

Use a hoist or other suitable lifting equipment to support the weight of the power take-off. Attach lifting devices at several places or use cribbing to support the PTO in a horizontal position during removal.



### **CAUTION:**

The PTO is heavy. Use approved lifting eyes and procedures to prevent accident or injury.

### **8.1 Remove the PTO from the engine.**

- 8.1.1 Remove hand lever and other connections to the PTO.
- 8.1.2 Remove drive shaft or drive belts from PTO output shaft.
- 8.1.3 Remove the mounting bolts attaching PTO to flywheel housing, removing those located near the top last. The PTO should separate from the flywheel housing. If the PTO doesn't separate, gently pry the flanges apart until the housing is removed from the engine flywheel housing pilot diameter.



**WARNING:** Use care when removing the PTO from the engine to avoid damage to grease fittings, friction disc teeth, and other components.

### **8.2 Remove the clutch from the PTO**

- 8.2.1 Remove the pilot bearing from PTO shaft using a bearing puller.
- 8.2.2 Remove jam nut (on outside of bellhousing) in order to free grease fitting.
- 8.2.3 Bend hub lock washer tab away from hub locknut.
- 8.2.4 Remove hub locknut.
- 8.2.5 Remove hub lock washer.
- 8.2.6 Remove the clutch assembly using a gear puller and the tapped holes that are provided in the hub & backplate.
- 8.2.7 Remove the grease hose and fittings from the clutch assembly.
- 8.2.8 Remove cotter pins, straight pins, and any washers from the clutch assembly, allowing the sliding sleeve and collar to separate from the clutch.
- 8.2.9 Remove (2) nuts and bolts securing the brass collar halves to the sliding sleeve.
- 8.2.10 Push or pull clutch adjusting lock and remove adjusting collar from clutch.

### **8.3 Remove the shaft from the PTO housing**

- 8.3.1 Remove the bearing adjustment lock (for 18" remove bearing retainer bolts).

- 8.3.2** Remove bearing adjustment nut from PTO housing (for 18" remove bearing retainer from housing).
- 8.3.3** Strike output end of shaft with soft faced hammer or use a suitable bearing press to loosen shaft and bearings from PTO housing. See sketch on page 7 for direction.
- 8.3.4** Remove inner cup and shaft with bearings from PTO housing.
- 8.3.5** Drive outer cup from PTO housing by placing a punch through (2) access holes provided in rear of the housing (does not apply to 18").
- 8.3.6** Using a suitable bearing press, remove bearings from shaft.

## **9.0 Assemble the PTO**

- 9.1 Reverse steps 8.3.1 through 8.3.6 on page 10 and 11.**
- 9.2 Adjust main bearings for proper PTO shaft axial endplay as indicated in steps 7.2.1 through 7.2.14 on page 9 (does not apply to 18").**
- 9.3 Install clutch by reversing steps 8.2.1 through 8.2.10 on page 10.**
- 9.4 Adjust clutch as indicated in steps 7.1.1 through 7.1.9 on pages 8 and 9.**

## 10.0 Warranty

### WPT POWER CORPORATION STANDARD TERMS AND CONDITIONS OF SALE

**1. PRICES, TERMS OF PAYMENT, TAXES.** All quoted prices are prices in effect on the invoice date (unless quoted otherwise), or date of completion if shipment is deferred on purchaser's instructions, are F.O.B. point of shipment unless otherwise specified, and are subject to change without notice. Terms are net thirty (30) days to those with an established credit standing with WPT or who are satisfactorily rated in commercial reference books. WPT is not required to accept sales on open account and may choose to request C.O.D. payment. WPT also requires a substantial deposit for special or non-stock purchases. Minimum billing is \$25.00. Interest at the maximum allowable rate will be charged on all delinquent accounts. No discount will be allowed for prompt payment. Prices set forth on the face hereof do not include duty, sales or use taxes. Any duty, sales or use taxes that WPT is obligated by law to collect will be added to the invoice price. Payment shall be made to WPT at its offices in Wichita Falls, Wichita County, Texas, USA and shall not be considered paid until WPT receives United States Legal Tender at the address listed on the face hereof.

**2. QUOTATIONS.** Quotations are given for prompt acceptance and are valid for 60 days unless otherwise agreed in writing. Quotations are generally held as price reference for a possible order and will not be binding unless otherwise agreed upon in writing. The submission of a quotation by WPT in response to purchaser's request, does not constitute an expression of acceptance of any term or condition which may have been set forth in purchaser's request. The terms and conditions of sale set forth herein are the only terms and conditions applicable to the sale of the products described on the face hereof, notwithstanding prior references.

**3. INVOICE.** Where WPT does not issue either a quotation or a sales confirmation and ships products pursuant to purchaser's purchase order, such sale shall be subject to WPT's Standard Terms and Conditions of Sale as set forth on WPT's invoice. Any additional or different terms or conditions of sale set forth in the purchase order or other communication from purchaser are objected to by WPT and shall not be effective nor binding unless assented to in writing by an officer of WPT.

**4. WARRANTY.** WPT guarantees all products will leave the factory in good condition. The products are warranted against defects in workmanship and material for a period of 365 (one year) after shipment. Adjustment under this warranty will be made only after completion of inspection of the part or product in our factory. Liability under the warranty shall extend only to the replacement or correction of any defective part or product as determined by WPT. All materials must be returned freight prepaid. This warranty shall not apply to any product that has been repaired or altered without the specific knowledge and consent of an authorized representative of the manufacturer; or operated or installed in a manner contrary to the manufacturer's instruction; or subjected to misuse or improper maintenance; or has been damaged by accident or negligence. This warranty is made in lieu of all other warranties, expressed or implied, including but not limited to warranties of merchantability or fitness for a particular purpose, and there are no other warranties that extend beyond this expressed warranty. WPT reserves the right to discontinue models or to change specification at any time without notice. No discontinuance or change will create any liability on the part of WPT in respect to its products in the hands of customers or products on order not incorporating such changes even though delivered after any such change. Rotating equipment is potentially dangerous and should be properly guarded. The user should check for all applicable safety codes and provide suitable guarding.

**5. RETURNS AND CANCELLATIONS.** No purchase order with respect to which WPT has issued or indicated a sales confirmation may be canceled or the manufacture of products thereunder suspended after the date of the sales confirmation without written consent of WPT. WPT's consent may, at its option, be predicated upon a cancellation charge. Upon such cancellation or suspension at the request of purchaser, purchaser agrees to reimburse WPT promptly for all expenditures for material used, labor and engineering services performed, or for which WPT has obligated itself, a proportionate share of direct manufacturing, engineering, selling, general and administrative expenses included in connection with such purchase order so far as it has been contemplated, and the proportionate amount of the normal profits which would have been earned under the purchase order. In addition, purchaser shall also reimburse WPT for any extraordinary costs and other expenses attributable to such suspension or cancellation.

In case products are rejected on inspection by purchaser, WPT must be notified in writing within fifteen (15) days from receipt of the product or WPT shall have no obligation to correct such defect. WPT shall then have the option of re-inspection at purchaser's plant or its own before allowing or disallowing purchaser's claim. Defects that do not impair service shall not be a cause for rejection, or recovery under any warranty.

NO PRODUCTS SHALL BE RETURNED TO WPT (WHETHER DUE TO CANCELLATION OF A PURCHASE ORDER OR FOR ANY OTHER REASON NOT THE FAULT OF WPT) WITHOUT PRIOR WRITTEN AUTHORIZATION FROM WPT. An inspection and restocking charge on all returned items will, at WPT's option, be required. Any request to return products shall include, in addition to other information reasonably requested by WPT, a full description of the products, the date of the purchase order and WPT's invoice number.

**6. SHIPMENT.** Unless otherwise specified herein, all shipments are F.O.B. or F.A.S. point of shipment indicated on the front hereof. WPT's responsibility for shipment terminates upon the delivery of products herein referred to, the title thereto and any risk of loss, shall be considered as being transferred to the purchaser upon delivery to the common carrier for transportation to the purchaser and title to the products shall not revert to WPT by operation of law for any purpose. No claims for shortages, damages or failure in delivery, whether by common carrier, parcel post or otherwise, may be made by the purchaser against WPT. In the absence of written shipping instructions from purchaser, WPT may ship the products freight collect to the purchaser upon delivery to the common carrier for transportation by any common carrier which it considers satisfactory or, if appropriate, in the opinion of WPT, by parcel post. WPT hereby retains a purchase money security interest in the products to secure the payment of the purchase price. Purchaser agrees that a reproduction hereof may be filed by WPT as a financing statement at any time. Except as provided on the face hereof or as hereinafter provided, prices include packing for products destined within continental limits of the United States, Canada, and Mexico. An additional charge may be made for crating and for export packing and crating. All scheduled delivery dates are estimated based on a normal work load and all deliveries are subject to change without liability to WPT.

**7. MISCELLANEOUS.** None of the Standard Terms and Conditions of Sale herein set forth may be added to, modified, superseded or otherwise altered except by a written instrument signed by an officer of WPT and delivered by WPT to purchaser. Each shipment received by purchaser from WPT shall be deemed to be upon the terms and conditions herein set forth, except as they may be added to, modified, superseded or otherwise modified as provided above, notwithstanding any terms and conditions that may be contained in any purchase order or other form of purchase, and notwithstanding purchaser's act of accepting or paying for the products or similar act of purchaser.

No agent, employee, or representative of WPT has any authority to bind WPT to any affirmation, representation or warranty concerning goods sold. Unless an affirmation, representation or warranty made by agent, employee or representative is specifically included within a written agreement and signed by an officer of WPT, it shall not be enforceable by purchaser.

Any typographical or clerical error herein is subject to correction.

This document and the sale of the products described herein shall be construed in accordance with the laws of the State of Texas.

WPT will not be liable for any losses or delays resulting from fire, flood, storm, strikes or other circumstances beyond its control which affect its operation or the operations of its suppliers.

## 11.0 Bolt Torque Values

TORQUE VALUES FOR SOCKET HEAD AND HEX HEAD CAPSCREWS						
SOCKET HEAD CAP SCREWS						
BOLT SIZE IN INCHES	As Received			Lubricated**		
	LB - FT	LB - IN	Nm	LB - FT	LB - IN	Nm
1/4	13	150	17	10	120	13
5/16	23	305	34	18	244	27
3/8	45	545	62	36	436	49
7/16	70	840	95	56	672	76
1/2	108	1300	147	86	1040	117
9/16	155	1860	210	124	1488	168
5/8	211	2530	286	168	2024	228
3/4	367	4400	497	293	3520	397
7/8	583	7000	791	466	5600	632
1	867	10400	1175	693	8320	940
1 1/8	1242	14900	1684	993	11920	1347
1 1/4	1750	21000	2374	1400	16800	1899
1 3/8	2317	27800	3142	1853	22240	2513
1 1/2	3042	36500	4125	2433	29200	3300
1 3/4	4950	59400	6714	3960	47520	5371
2	7492	89900	10161	5993	71920	8128
HEX HEAD CAP SCREWS - Grade 8						
BOLT SIZE IN INCHES	As Received			Lubricated**		
	LB - FT	LB - IN	Nm	LB - FT	LB - IN	Nm
1/4	8	100	11	6	80	9
5/16	17	200	23	13	160	18
3/8	30	360	41	24	288	32
7/16	48	570	64	38	456	51
1/2	83	990	112	66	792	89
9/16	107	1285	145	85	1028	116
5/8	143	1714	194	114	1371	155
3/4	256	3070	347	204	2456	277
7/8	417	5000	565	333	4000	452
1	625	7500	848	500	6000	678
HEX HEAD CAP SCREWS - Grade 5						
BOLT SIZE IN INCHES	As Received			Lubricated**		
	LB - FT	LB - IN	Nm	LB - FT	LB - IN	Nm
1/4	6	71	8	5	56	6
5/16	12	142	16	9	113	12
3/8	22	260	29	17	208	23
7/16	34	410	46	27	328	36
1/2	53	636	72	42	508	57
9/16	74	890	101	59	712	80
5/8	104	1250	141	83	1000	112
3/4	183	2200	249	146	1760	199
7/8	298	3570	403	238	2856	322
1	440	5280	597	352	4224	477
1 1/8	553	6640	750	442	5312	600
1 1/4	775	9300	1051	620	7440	840
1 3/8	1012	12140	1372	809	9712	1097
1 1/2	1350	16200	1831	1080	12960	1464

\*\* NOTE: For loctite use lubricated values

Chart 1

## 12.0 Specifications and Duty Service Classification

### SPECIFICATIONS

Model/ Size	Available SAE Housing Sizes	Maximum Input Torque lb-ft (Nm)	Duty Service Classification				Maximum Speed rpm <sup>2</sup>	Approx. Net Weight lbs (kgs)
			Maximum Clutch Ratings hp (Kw) <sup>1</sup>					
			Class 1	Class 2	Class 3	Class 4		
<b>C106</b>	6,5,4	160 (217)	40 (30)	28 (21)	20 (15)	3500	53 (24.0)	
<b>C107</b>	6,5,4	177 (240)	57 (43)	38 (28)	28 (21)	3200	56 (25.4)	
<b>C108</b>	5,4,3	230 (312)	68 (51)	45 (34)	34 (25)	3100	73 (33.1)	
<b>C110</b>	4,3,2	329 (446)	98 (73)	65 (49)	49 (37)	3400	117 (53.1)	
<b>SP111</b>	3,2,1	452 (613)	128 (95)	85 (63)	64 (48)	3200	143 (64.9)	
<b>SP211</b>	3,2,1	904 (1226)	255 (190)	170 (128)	128 (95)	3200	157 (71.2)	
<b>SP311</b>	3,2	1620 (2200)	383 (286)	252 (188)	189 (141)	3200	223 (101.2)	
<b>SP114</b>	1,0	800 (1085)	194 (145)	125 (93)	94 (70)	2400	263 (119.3)	
<b>SP214</b>	1,0	1600 (2170)	388 (289)	252 (188)	190 (142)	2400	332 (150.6)	
<b>SP314</b>	1,0	2400 (3255)	582 (434)	374 (279)	281 (210)	2400	413 (187.3)	
<b>SP318</b>	0	6000 (8137)	936 (698)	627 (468)	463 (345)	1800	780 (353.8)	

<sup>1</sup> Horsepower (Kw) ratings may be increased with optional clutch plates.

<sup>2</sup> Contact WPT Engineering for applications requiring higher speeds.

### Duty Service Classifications<sup>3</sup>

#### Class 1

Primarily used as a disconnect clutch. Light loads with minimal slip.

#### Class 2

Primarily used as a disconnect clutch. Light to medium loads with a maximum 2 second slip before engagement.

#### Class 3

Used to start medium loads. Maximum 3 second slip before engagement.

#### Class 4

Used to start heavy loads. Maximum 4 second slip before engagement.

<sup>3</sup> If in doubt of proper duty service class to use, consult WPT Engineering for application assistance. Attention must also be paid to the maximum speed rating and side load capacities, in addition to clutch ratings. Clutch ratings are based on engagement at low idle speed and, once engaged, clutch must be engaged for at least one hour before disconnecting.

### CHART 2

### 13.0 Flywheel and Housing Dimensions

<b>FLYWHEEL DIMENSIONS</b>					
Clutch size	Flywheel Dimensions				
	"A"	"B"	"C"	N1	H1
6"	7.25 (184.2)	8.500 (215.90)	7.875 (200.02)	6	5/16 – 18 NC
7"	8.12 (206.2)	8.750 (222.25)	9.500 (241.30)	8	5/16 – 18 NC
8"	8.88 (225.6)	9.625 (244.48)	10.375 (263.52)	6	3/8 – 16 NC
10"	10.88 (276.4)	11.625 (295.28)	12.375 (314.32)	8	3/8 – 16 NC
11"	12.38 (314.5)	13.125 (333.38)	13.875 (352.42)	8	3/8 – 16 NC
14"	16.12 (409.4)	17.250 (438.15)	18.375 (466.72)	8	1/2 - 13 NC
18"	19.62 (498.3)	21.375 (542.93)	22.500 (571.50)	6	5/8 – 11 NC
<b>FLYWHEEL HOUSING DIMENSIONS</b>					
Housing size	Housing Dimensions				
	"D"	"E"	N2	H2	
"6"	10.500 (266.70)	11.250 (285.75)	8	3/8 – 16 NC	
"5"	12.375 (314.33)	13.125 (333.38)	8	3/8 – 16 NC	
"4"	14.250 (361.95)	15.000 (381.00)	12	3/8 – 16 NC	
"3"	16.125 (409.58)	16.875 (428.63)	12	3/8 – 16 NC	
"2"	17.625 (447.68)	18.375 (466.73)	12	3/8 – 16 NC	
"1"	20.125 (511.18)	20.875 (530.22)	12	7/16 - 14 NC	
"1/2"	23.000 (584.20)	24.375 (619.12)	12	1/2 - 13 NC	
"0"	25.500 (647.70)	26.750 (679.45)	16	1/2 - 13 NC	
"00"	31.000 (787.40)	33.500 (850.90)	16	1/2 – 13 NC	

**CHART 3**

See page 15 for flywheel and housing drawing.

## 14.0 Flywheel and Housing Drawing

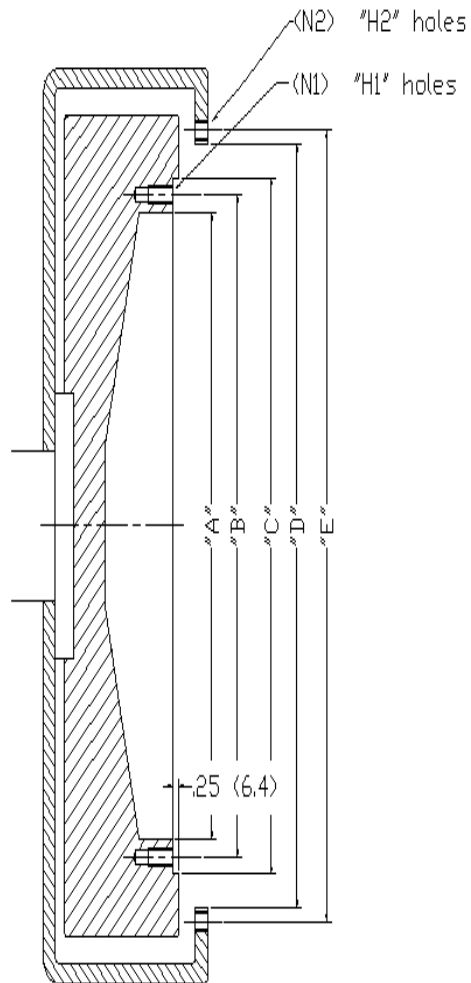



# 15.0 WTD-SP Style PTO Exploded View Drawing

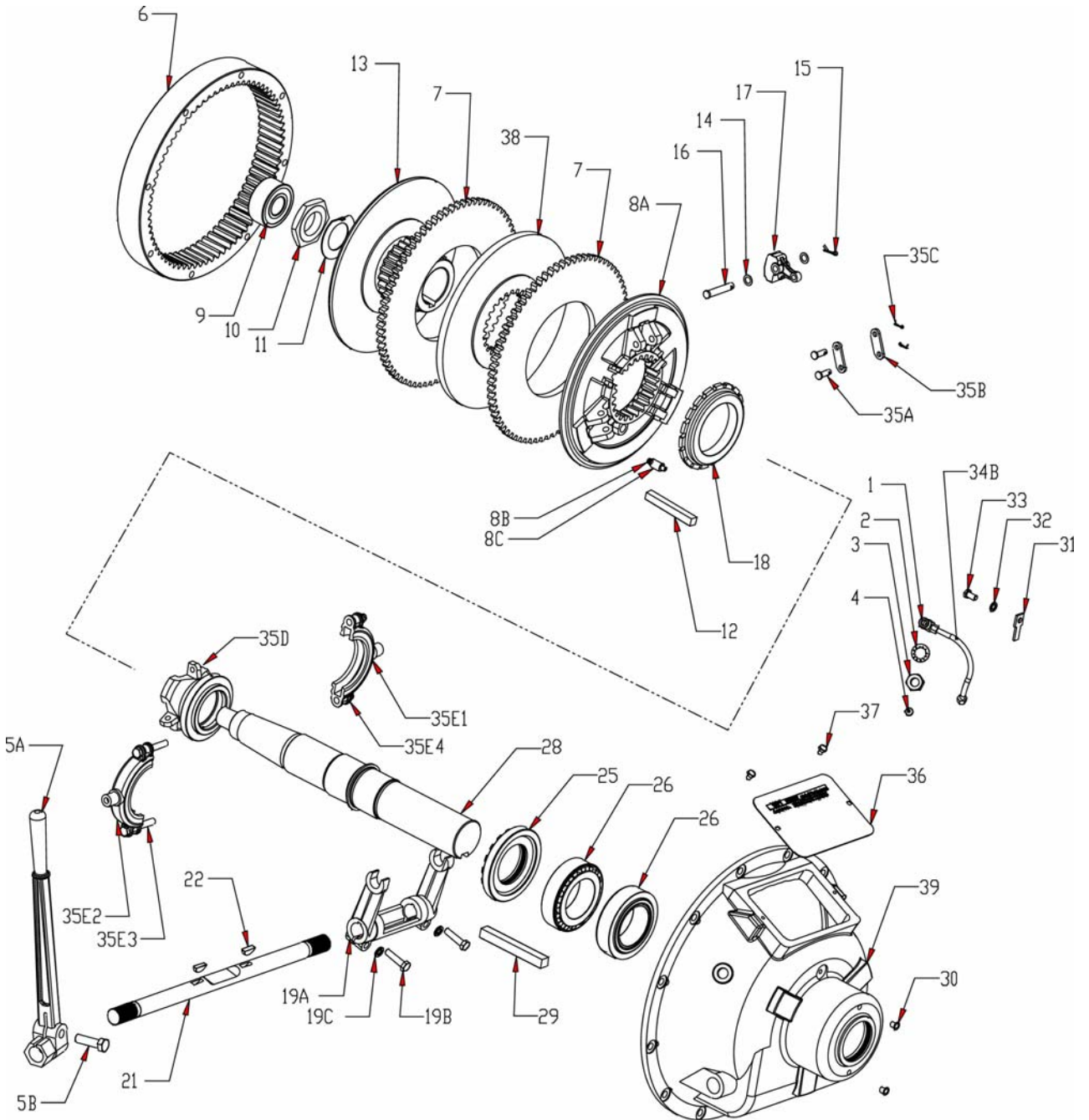

# 16.0 WTD-SP Style PTO Drawing and Parts List

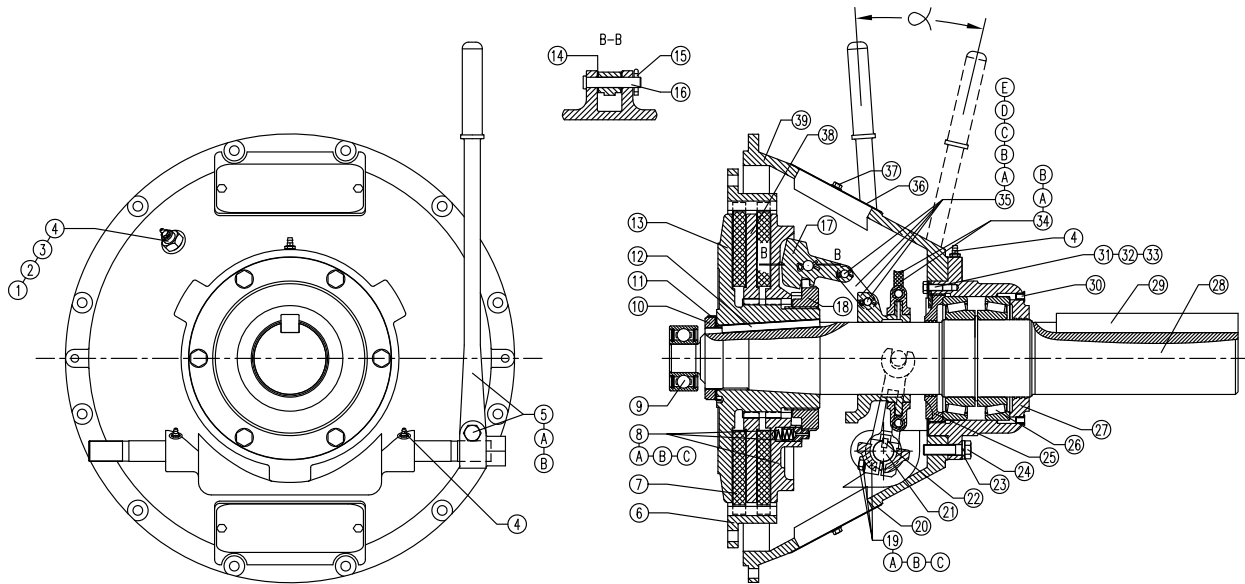

Item	Description	Qty	Item	Description	Qty
1.	Bushing, grease	1	22.	Key, woodruff	2
2.	Washer, lock	1	23.	Washer, lock	6
3.	Nut	1	24.	HHCS	6
4.	Zerk, grease	4	25.	Retainer, bearing	1
5.	Assembly, lever, hand	1	26.	Bearing, roller, tapered	2
	A. Lever, hand	1	27.	Carrier, bearing	1
	B. HHCS	1	28.	Shaft, clutch	1
6.	Ring, drive	1	29.	Key, output shaft	1
7.	Disc, friction	2	30.	Plug, polyethylene	2
8.	Assembly, plate, floating	1	31.	Lock, bearing retainer	1
	A. Plate, floating	1	32.	Washer, lock	1
	B. Spring, adjusting	1	33.	HHCS	1
	C. Pin, adjusting	1	34.	Assembly, hose	1
9.	Bearing, pilot	1	A. Elbow	1	
10.	Nut, hub	1	B. Hose, flexible	1	
11.	Lock washer, hub	1	35.	Assembly, sliding sleeve	1
12.	Key, clutch	1	A. Pin, clevis	8	
13.	Hub and backplate	1	B. Link, lever	8	
14.	Washer, spring	8	C. Pin, cotter	8	
15.	Pin, cotter	4	D. Sleeve, sliding	1	
16.	Pin, clevis	4	E. Assembly, collar ***	1	
17.	Lever	4	36.	Nameplate, instruction	1
18.	Ring, adjusting	1	37.	HHCS	4
19.	Assembly, yoke	1	38.	Plate, center	1
A.	Yoke	1	39.	Bellhousing	1
B.	HHCS	2			
C.	Washer, lock	2			
20.	Nameplate	1			
21.	Shaft, operating	1			

\*\*\* Optional "Ball Bearing Collar" available for 11", 14" and 18" Power Take Off.

## 17.0 WTD-C Style PTO Drawing and Parts List

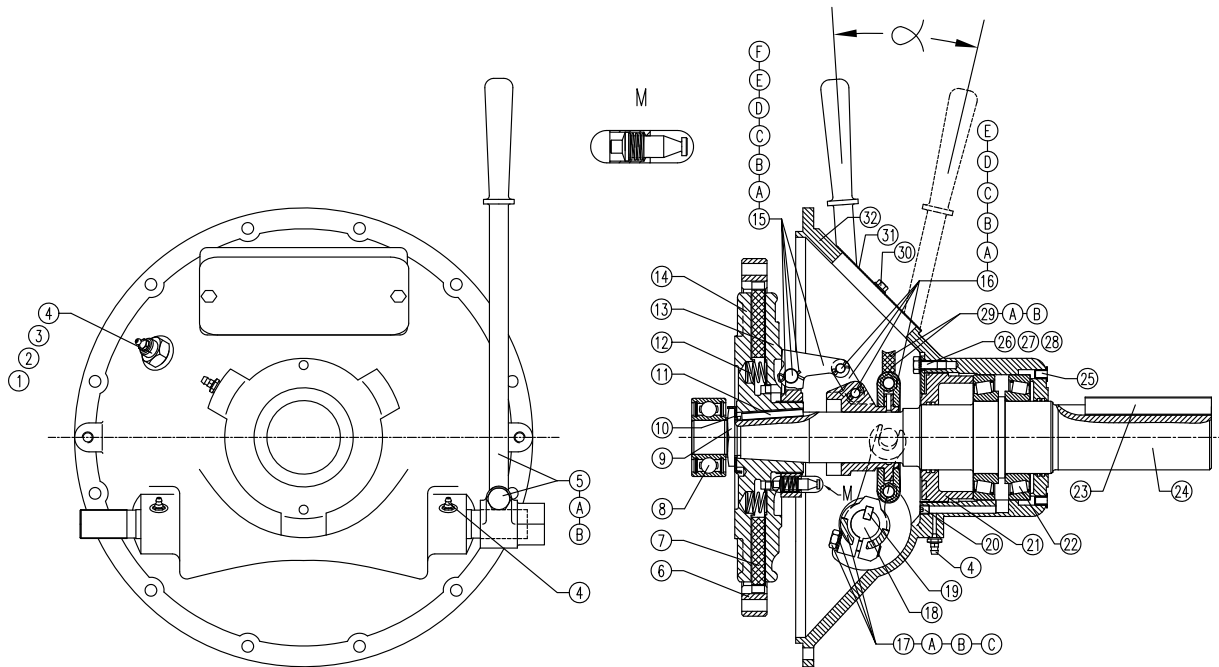

Item	Description	Qty	Item	Description	Qty
1.	Bushing, grease	1	D.	Sleeve, sliding	1
2.	Washer, lock	1	E.	Assembly, collar***	1
3.	Nut	1	17.	Assembly, yoke	1
4.	Zerk, grease	4	A.	Yoke	1
5.	Assembly, lever, hand	1	B.	HHCS	2
A.	Lever, hand	1	C.	Washer, lock	2
B.	HHCS	1	18.	Shaft, operating	1
6.	Ring, drive	1	19.	Key, woodruff	2
7.	Disc, friction	1	20.	Screw, Set	1
8.	Bearing, pilot	1	21.	Retainer, bearing	1
9.	Nut, hub	1	22.	Bearing, roller, tapered	2
10.	Lock washer, hub	1	23.	Key, output shaft	1
11.	Key, clutch	1	24.	Shaft, clutch	1
12.	Spring, release	6	25.	Plug, polyethylene	2
13.	Plate, floating	1	26.	Lock, bearing retainer	1
14.	Hub and backplate	1	27.	Washer, lock	1
15.	Assembly, lever, adjusting	1	28.	HHCS	1
A.	Spring, adjusting	1	29.	Assembly, hose	1
B.	Pin, adjusting	1	A.	Elbow	1
C.	Pin, cotter	4	B.	Hose, flexible	1
D.	Pin, clevis	4	30.	HHCS	2
E.	Lever, finger	4	31.	Nameplate, instruction	1
F.	Ring, adjusting	1	32.	Bellhousing	1
16.	Assembly, sliding sleeve	1			
A.	Pin, clevis	8			
B.	Link, lever	8			
C.	Pin, cotter	8			

\*\*\* Optional "Ball Bearing Collar" available for 10" and 11" Power Take Off.

## 18.0 WTD-SP Style 18" PTO Drawing and Parts List

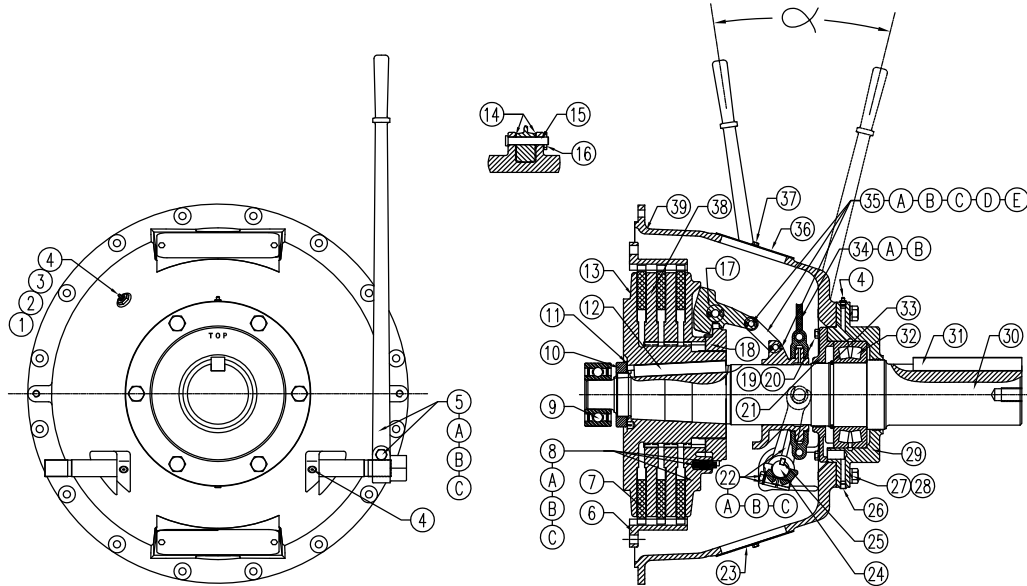

Item	Description	Qty	Item	Description	Qty
1.	Bushing, grease	1	23.	Nameplate, bottom	1
2.	Washer, lock	1	24.	Shaft, operating	1
3.	Nut	1	25.	Key, woodruff	2
4.	Zerk, grease	4	26.	Plug, pipe	1
5.	Assembly, lever, hand	1	27.	HHCS	6
A.	Lever, hand	1	28.	Washer, lock	6
B.	HHCS	1	29.	Carrier, bearing	1
C.	NUT	1	30.	Shaft, clutch	1
6.	Ring, drive	1	31.	Key, output shaft	1
7.	Disc, friction	3	32.	Bearing, roller, spherical	1
8.	Assembly, plate, floating	1	33.	Ring, snap	1
A.	Plate, floating	1	34.	Assembly, hose	1
B.	Spring, adjusting	1	A.	Elbow	1
C.	Pin, adjusting	1	B.	Hose, flexible	1
9.	Bearing, pilot	1	35.	Assembly, sliding sleeve	1
10.	Nut, hub	1	A.	Pin, clevis	8
11.	Lock washer, hub	1	B.	Link, lever	8
12.	Key, clutch	1	C.	Pin, cotter	8
13.	Hub and backplate	1	D.	Sleeve, sliding	1
14.	Washer, spring	8	E.	Assembly, collar ***	1
15.	Pin, clevis	4	36.	Nameplate, instruction	1
16.	Pin, cotter	4	37.	HHCS	4
17.	Lever	4	38.	Plate, center	2
18.	Ring, adjusting	1	39.	Bellhousing	1
19.	HHCS	6			
20.	Washer, lock	6			
21.	Retainer, bearing	1			
22.	Assembly, yoke	1			
A.	Yoke	1			
B.	HHCS	2			
C.	Washer, lock	2			

\*\*\* Optional "Ball Bearing Collar" available for 11", 14" and 18" Power Take Off.